

DAYTIME RUNNING LIGHTS FOR COACH AND CAR

This system has been proved to enhance driving safety and may someday be required on all vehicles on the road.

By CAROL F. MAXWELL & EDWIN S. GUROJIAN, F76350

While examining a recent vehicle insurance statement, we noted that our insurance company was offering a discount for vehicles equipped with daytime running lights (DRL). To qualify for the discount, the DRL had to be at *least* 70 percent of normal luminance and be fully automatic, with no on-off switch.

The safety benefits of driving in a vehicle that is more visible in the daytime have been reported in several

studies. Drivers involved in collisions often say, "I just didn't see him." These lights can increase your chances of being seen.

Some states require the use of headlights during rain, fog, or other inclement weather, and some recommend "lights on for safety."

In Canada, the use of DRL is law. Prevost Car Inc., in order to comply with the Canadian law, has offered a DRL system on its bus shells since 1990.

We modified the headlight circuit on our 1986 Prevost to

incorporate the features of the later models. This circuit illuminates the headlights at reduced power whenever the ignition is on, provided that the parking brake is *off* and the transmission is not in neutral. Our towed car, a 1989 Ford Escort, does not require the parking brake and transmission neutral override feature, because it has a standard transmission and is not left idling for extended periods.

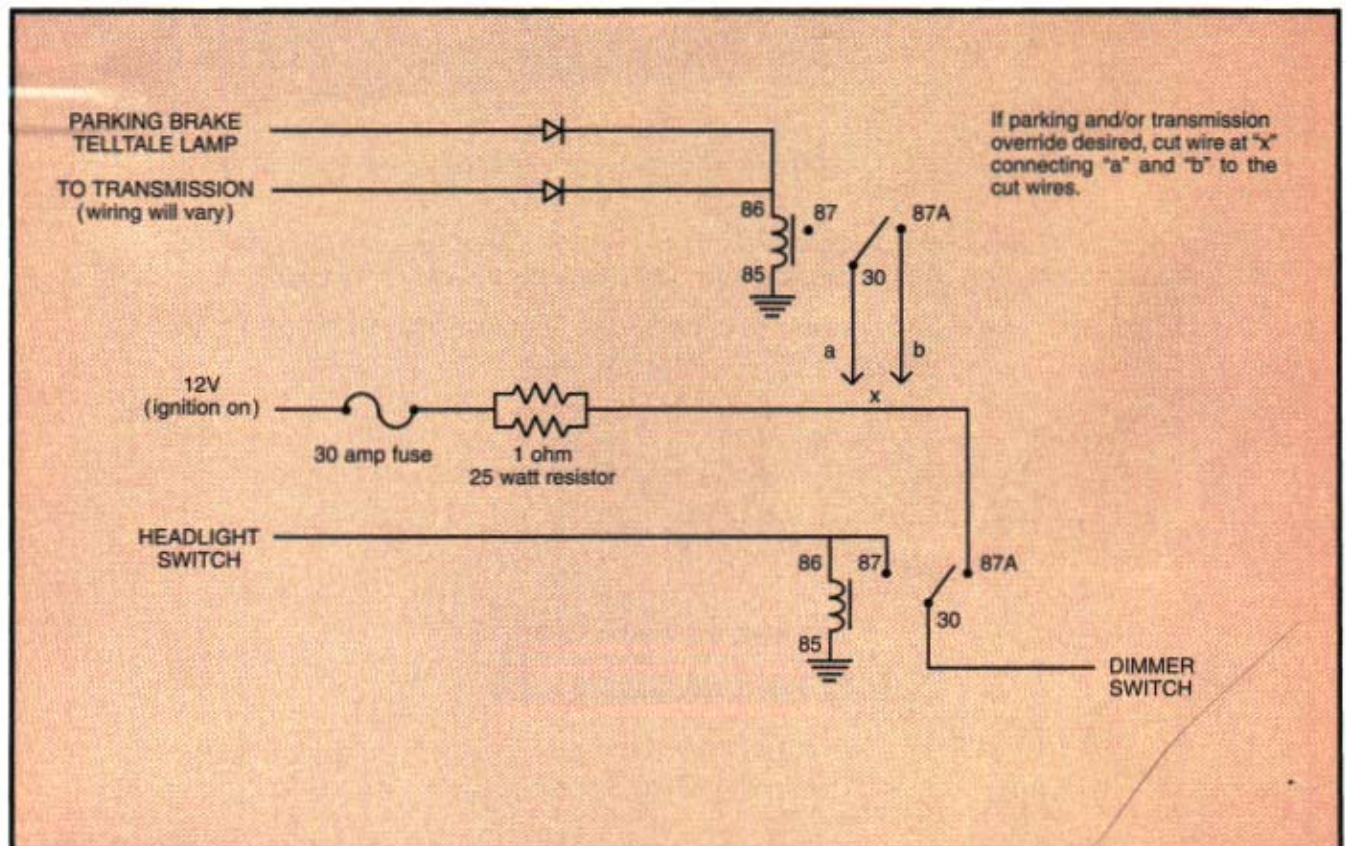

This simple system can improve on-the-road safety and may even offer the added bonus of saving you a few dollars on your insurance premium.

The steps described below are suitable for motorhomes and automobiles that have a single wire passing from the "headlight on" terminal of the headlamp switch to the dimmer switch. If desired, the parking brake and transmission-neutral default feature can be used. The component parts are available at many electronic supply stores, although RadioShack does not offer some of them.

The 25-watt resistors used in this modification generate a significant amount of heat, so it is important to *isolate* them from any heat-sensitive material or components. Moreover, we strongly suggest the use of a heat shield to enclose the resistors. We used hardware cloth, which is available at most hardware stores.

To make your own DRL system, follow these steps:

1. Disconnect the battery negative terminal from ground.

2. Identify the wire that **goes**

1 SPDT cubic relay, 30-amp rating
1 or 2 3-amp diode(s)
1 square foot of hardware cloth

from the headlamp to the dimmer switch.

3. If this wire is attached with a removable connector at one or both ends, detach the wire at one end and install a new wire where the original was removed. Otherwise, cut the wire.

4. Find a suitable location for the STDP cubic relay.

5. Extend the wires cut in step 3, as needed.

6. Identify the wire from the dimmer switch and connect it to terminal 30 of the cubic relay.

7. Identify the wire from the headlamp switch and connect it to terminal 87 and terminal 86 of the cubic relay.

8. At the main fuse panel, identify an "ignition on" only, 12-volt-DC source. If no source is readily available, use a fuse tap on one of the existing "ignition on" fuses. Be sure to use the "in" side of the fuse and not the "out" side. Attach a wire from that source through a 30-amp fuse and then through the two 1-ohm, 25-watt resistors that are wired in parallel; attach to terminal 87A of the cubic relay. Mount these resistors with plenty of clearance and inside a heat shield.

9. Connect terminal 85 on the cubic relay to ground.

10. Reconnect the battery negative terminal to ground.

To test the system:

1. Turn on the headlight switch. Lights should function normally.

2. Check the high and low beams.

3. Turn off the headlights.

4. Turn on the ignition. Headlights should be on at diminished intensity.

5. Leave the ignition on and turn the headlight switch on. Note increased intensity.

When the ignition is turned on, the 12-volt-DC current passes through the 30-amp fuse, through the resistors, to terminal 87A, which is in continuity with terminal 30, and from there to the headlights. The resistors reduce the intensity of the headlights, prolonging their life. When the headlights are turned on, the relay is activated, reconnecting the original headlight-to-dimmer switch circuit. The headlights burn at normal intensity. This circuit allows the use of the bright lights for signaling during DRL operation. Should there be a relay failure, headlight function both dim and bright is preserved at a slightly reduced intensity. In the event of a resistor failure, DRL operation will be lost until the resistors are replaced. The loss of one resistor usually will be followed in short order by the loss of the other. Also shown in the schematic is the optional parking brake override. This disables the DRL if the parking brake is applied.

This simple system can improve on-the-road safety and may even offer the added bonus of saving you a few dollars on your insurance premium.

Parts List

Basic DRL:

- 1 SPDT cubic relay, 30-amp rating
- 2 1-ohm, 25-watt resistors
- 1 fuse holder with 30-amp fuse (use blade or barrel type, depending on your application)
- 1 fuse tap

Parking brake and/or transmission override: